

Give your home the

ComfortEDGE™



Windows will change your world if you get it right.

You've been scouring the Internet, researching everything you need to create your dream home.

You know exactly how you want your home to look and feel.

It's your sanctuary away from the world.



You know a core element in creating your dream home is in the insulation.

Wall, floor and ceiling insulation is common these days. However, window and door insulation is a lot less common and definitely worth considering.

Windows and doors can let in up to 87% of heat during summer and let out up to 40% of heat during winter. Insulating your windows and doors is the last piece of the puzzle. This ensures your building envelope is completely insulated with no weak spots.

So how do you insulate your windows and doors?

ComfortEDGE™ is your first step towards insulating your windows and doors ensuring your dream home is:

- Thermally comfortable
- Light and bright
- More energy efficient

Give your home the ComfortEDGE™

Standard Frame

More exposed metal leads to more heat transferred

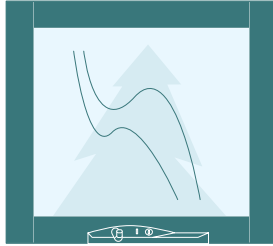

ComfortEDGE™

Embedded Technology

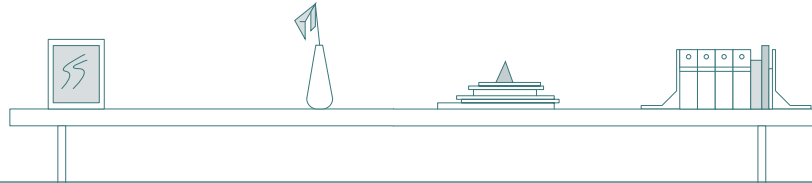
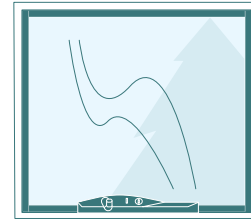

1 Incredible home insulation

ComfortEDGE™ is unlike anything currently on the market.

Due to its unique and patented design, it minimises heat transfer coming in and out of your home, making it more comfortable all year round. It's what we call high performing, due to its ability to insulate your home!

2 All about your view

ComfortEDGE™ combines minimalism and style. Using patented technology, the frame is embedded creating the illusion of space and a seamless connection between the outdoors and in. A stunning and modern aesthetic.

3 Affordable.

ComfortEDGE™ ticks all the boxes. It's stylish, high performing, allowing you to meet or exceed energy performance requirements and is extremely affordable. What makes it more affordable is our patented design and technology.

ComfortEDGE™ revolutionary in performance, styling and affordability!

Design integrity and reliability.

ComfortEDGE™ is a highly energy efficient window and door system complimented by a minimalist style aesthetic.

By embedding the structural aluminium window into the surrounding timber frame, the thermal performance of the window is greatly improved while offering increased strength and improved durability.

Our ComfortEDGE™ windows and doors have undergone physical testing to ensure we can stand behind the thermal performance numbers for these products. We know they are going to work the way we

say they will because we've tested them.

Knowing the data and performance is consistent for ComfortEDGE™, gives you peace of mind that the home you build will perform the way it's supposed to.

All testing performed in National Fenestration Rating Council (NFRC) accredited laboratories.





Applications

New Builds

With compliance requirements getting more and more stringent, ComfortEDGE™ is an excellent window and door solution.

Incorporating double glazing as standard, ComfortEDGE™ is the way of the future with new builds demanding better insulation.

Combined with embedded technology, ComfortEDGE™ is stylish, affordable and easy to install.

Ideal for residential applications using standard aluminium framing.

Replacement or Retrofit Projects

ComfortEDGE™ is suitable for use in replacement or retrofit projects. This allows your old windows and doors to be removed and replaced with ComfortEDGE™. Because the ComfortEDGE™ reveal is positioned in line with the frame, replacement is simplified, particularly in brick veneer applications which can be more difficult.

Replacing old, inoperable, and inefficient windows and doors will provide the following benefits:

- A modern facelift for your home or apartment
- Windows and doors that open easily and effortlessly
- Windows and doors that make your home more thermally comfortable
- Windows and doors that make your home more energy efficient

Replacing your windows and doors is an affordable and easy way to improve your home – and its value.

ComfortEDGE™ 753 Sliding Window

MAXIMUM PANEL HEIGHT*	1500mm
MAXIMUM PANEL WIDTH*	1000mm
MAXIMUM GLASS THICKNESS	≤ 20mm
U VALUE RANGE	2.6-3.6
SHGC RANGE	0.23 - 0.61

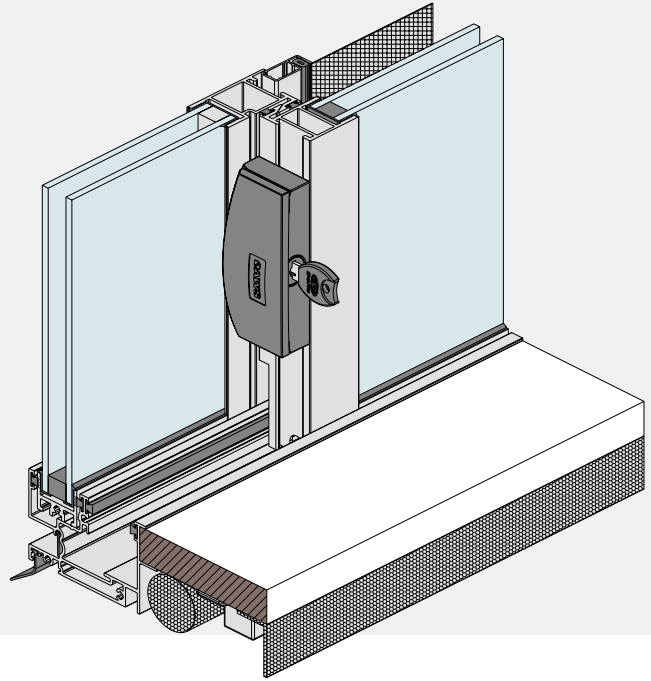

Key Features

- Series 753 ComfortEDGE™ sliding window is an energy efficient window system designed to reduce the visibility of the aluminium frame.
- The sash is concealed below the reveal and maintains the same sightlines as the fixed lights. This greatly enhances thermal performance by reducing the exposed internal aluminium frame and gives a clean, minimalist, architectural look on both the inside and outside.
- The window has a unique, patent thermal seal that greatly reduces thermal transmission through the window. The window can also be fitted with twin reveals for conventional window installation.
- Optional meeting stiles, mullions and transoms strengths cover a large variety of design and wind load performance requirements.
- Accepts double glazed 20mm IGUs allowing the inclusion of high performance glazing systems for superior energy efficiency and comfort.
- Tested to comply with Safe4Kids restricted opening requirements in accordance with the National Construction Code.

* Dimensions subject to individual site conditions.

ComfortEDGE™ 755 Awning Window

Note: Maximum panel height and width of Awning sashes are interdependent.

MAXIMUM PANEL HEIGHT* < 900MM WIDE	2053mm
MAXIMUM PANEL WIDTH* < 800MM HIGH	2353mm
MAXIMUM GLASS THICKNESS	≤ 20mm
U VALUE RANGE	2.32 - 3.22
SHGC RANGE	0.22 - 0.57

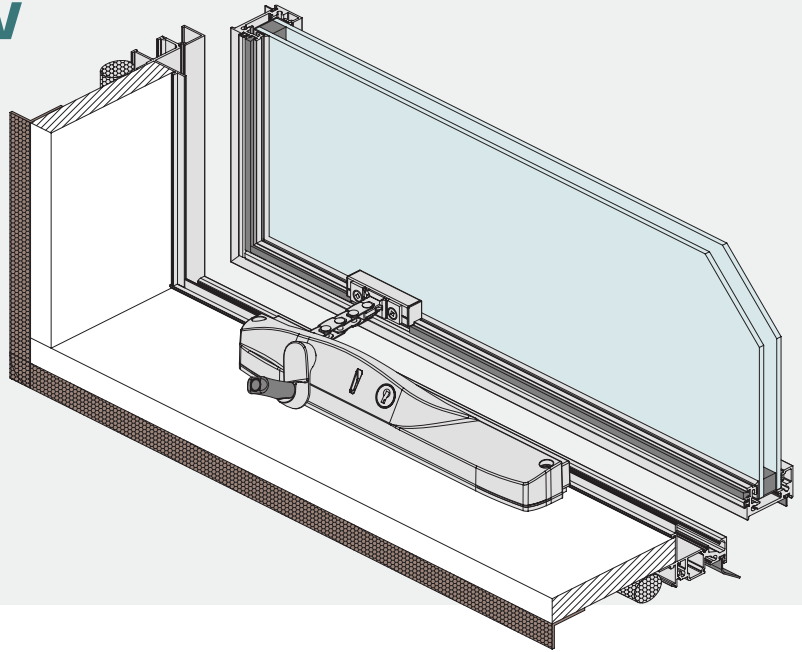

Key Features

- 75mm aluminium awning window designed for optimal thermal performance.
- ComfortEDGE™ reveal delivers a minimalist design aesthetic and optimised vision plane through the window.
- Thermal performance is achieved by reducing the exposed internal aluminium frame and its ability to transfer energy through it.
- Patented chain winder adaptor brackets keep the body of the sash concealed below the reveal and maintain the same sightlines as fixed lights.
- Accepts double glazed 18-20mm IGUs for excellent thermal performance.
- 75mm frame provides excellent strength and weather performance achieving a water resistance rating of 600pa.
- Flyscreens can be fitted without the need for additional trims, delivering a refined finish.
- The frame can be fabricated either square cut or mitre for a more architectural appearance.
- Tested for compliance with Australian Standard AS2047

* Dimensions subject to individual site conditions.

ComfortEDGE™ 759 Sliding Door

MAXIMUM PANEL HEIGHT*	3000mm
MAXIMUM PANEL WIDTH*	2000mm
MAXIMUM GLASS THICKNESS	≤ 24mm
UW VALUE RANGE	2.02 - 3.6
SHGC RANGE	0.23 - 0.67

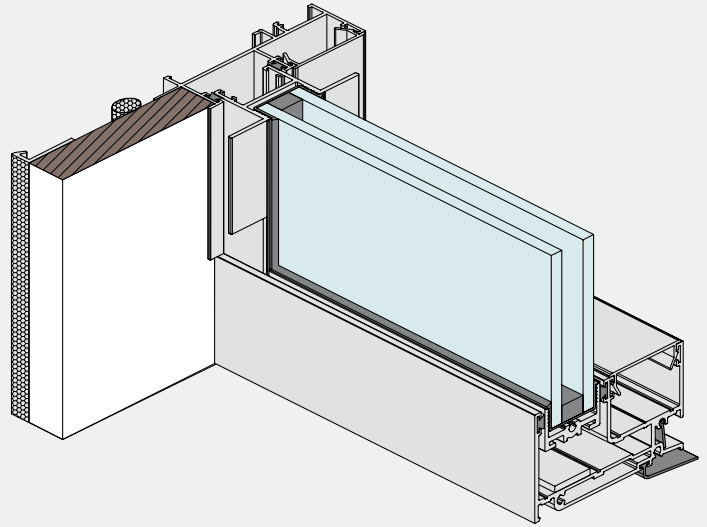

Key Features

- Series 759 ComfortEDGE™ sliding door is an energy efficient door system designed to have minimised sightline from the aluminium frame and panel.
- The top and bottom rails and jamb stiles use embedded technology to conceal the perimeter frame and greatly improve thermal performance by reducing the amount of exposed frame.
- Embedded technology delivers a clean, architectural finish, uninterrupted sightlines and outstanding thermal performance.
- A custom stainless steel, flat running track combined with custom stainless steel rollers with leading track brush ensures track delivers optimal, long term operating performance.
- This double glazed system will accept 22mm and 24mm IGUs with a maximum panel weight of 320kg.
- Optional heavy duty bottom rails and running track can be selected for high exposure areas and extra wide spans to improve overall strength to suit almost any application.
- Up to 5 track sill configurations are available to suit extra wide openings up to 19m wide.
- Tested for compliance with Australia Standard AS2047.

* Dimensions subject to individual site conditions.



Tested Systems

All ComfortEDGE™ window and doors systems are tested to comply with relevant standards and the National Construction Code (NCC).



Energy

All ComfortEDGE™ window and doors systems are WERS rated and tested and considered an energy efficient option.

In addition to being WERS rated all ComfortEDGE™ products have been physically tested in NFRC laboratories to ensure their thermal performance.



Safe4Kids

Our Safe4Kids™ products have been tested to comply with the requirements set out by the NCC for operable windows in elevated applications.



AS2047

To ensure performance in all weather, all ComfortEDGE™ window and doors systems meet or exceed the requirements of AS2047 for materials, construction, strength, water and airtightness.

The Right Glass









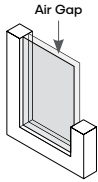

Choosing the right glass for your windows and doors can pay big dividends in energy efficiency and comfort levels.

Glass not only insulates you from temperature extremes, it also controls the passage of light and heat in and out of your home.

There are five key considerations when thinking about glass for your home.

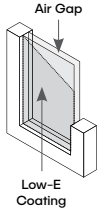
- Natural light
- Heat gain
- Heat loss
- Safety and security
- Acoustics

High performance glass can be used to reduce noise, overcome site limitations and demanding window orientations, and control UV and glare without compromising your building's energy efficiency.

Glazing type		Attributes	Glare Reduction	Solar Heat Performance	Insulation/ Energy Efficiency
	Double Glaze	Insulated Glazing Unit (IGU) thickness - 755: 18-20mm / 753: 20mm Improved solar heat reduction over single glazing. Improved insulation over single glazing.			
	Double Glaze Toned	Insulated Glazing Unit (IGU) thickness - 755: 18-20mm / 753: 20mm Improved solar heat reduction over clear double glazing Up to 32% more effective than clear IGUs. Improved insulation over single glazing.			
	Double Glaze Low E Softcoat or Hardcoat	Insulated Glazing Unit (IGU) thickness - 755: 18-20mm / 753: 20mm High performance insulating glass with inert gas fill as standard. Developed specifically for high energy efficiency and solar heat reduction performance.			

KEY  Good  Better  Best

The performance ratings indicated in the table is that of the highest performing product in that category for that characteristic. Performance will differ by product and suitability of each product for your application will differ according to the environment and location of use.

For detailed glass performance data contact your local Vantage® supplier.



Talk to us.

We're passionate about quality workmanship and exceptional customer service.

We offer specialist advice and custom designed windows and doors.

Contact us to discuss your next project.

Australian made aluminium windows & doors.



For more information and to find your local Vantage® suppliers, visit:

vantagewindows.com.au

For design inspiration & tips, follow us:

 [vantagewindowsaus](https://www.instagram.com/vantagewindowsaus)

 [vantageaustralia](https://www.facebook.com/vantageaustralia)



ABN 48 067 950 903

HEAD OFFICE

76-78 Jedda Road,
Prestons NSW 2170

PO BOX 311
Liverpool NSW 1871

HAVE QUESTIONS?

Call us at 1300 026 189 or email marketing@awsaustralia.com.au

